



*Pride in Service with Integrity*

**Date:** September 15<sup>th</sup> 2011

DGP11 - 136

**To:** Mr. Robert Baldwin  
City Manager  
City of Dania Beach

**From:** Chief Donn G. Peterson  
Dania Beach District  
Special Weapons and Tactics

**Subject:** LAW ENFORCEMENT TRUST FUND REQUEST  
FITNESS CENTER EQUIPMENT

This memorandum is being submitted to request the expenditure of LETF dollars for the purchase of capital equipment for use in the Dania Beach District.

Physical fitness is a vital component of deputy performance, morale, longevity, and wellness. Proposed is the purchase of fitness equipment for a gym at our district headquarters building, which is located at 4601 Southwest 30<sup>th</sup> Avenue. This request includes all of the equipment necessary to have a modest, but functional gym available to personnel assigned to the command 24 hours a day. It's noteworthy that in the 23-year history of this command, there has never been a fitness center available to personnel. This was due in large part to a lack of facility; however, we recently moved into a new headquarters building, which has a designated fitness center albeit without equipment. Due to the anticipated cost, we sought proposals and quotes from several different vendors. Two responded and based upon a number of factors, it is the consensus of the men and women of the Dania Beach District that the proposal from *Precor* is most suitable for our needs. Both of the proposals and quotes have been attached for comparison purposes with the one from *Precor* foremost. If approved, the total amount of this request would not exceed \$24,000.00. Additionally, I have attached our most recent LETF balance sheets from the City of Dania Beach showing a balance of \$51,541.00 in state funds and \$131,295.00 in federal funds.

I would appreciate it if you would favorably endorse this request and am prepared to discuss this matter with you at your convenience.

/dgp

Attachments

cc: Major John Hale  
Commander Mike Grimm  
Lieutenant Diana Brown  
Ms. Felecia Brown  
File



# Busy Body Gyms to Go

Commercial Exercise Equipment of South Florida

South Florida's Authorized Exclusive Distributor of Precor & Icarian Commercial Fitness Products

910 SW 2nd Place, Pompano Beach, FL 33069  
Phone: 954-781-1787 Fax: 954-781-1575  
Website: www.gymstogo.com

# Quotation/ Order Form

Order Type

SPECIAL ORDER

**BILL TO:** BROWARD COUNTY SHERIFF  
DANIA BEACH DISTRICT

**SHIP TO:** \_\_\_\_\_  
REVISED AS OF 09/01/2011

**Attn:** LT.DIANA BROWN  
**Phone:** 9540926-3282/ CELL 954-816-1342  
**Email:** donn\_pterson@sheriff.org  
**Email:** diana\_brown@sheriff.org

**Attn:** \_\_\_\_\_  
**Phone:** \_\_\_\_\_  
**Quotation Valid Until:** September 15, 2011

ITEM(S) REQUESTED	(REG. PRICE)	QTY	UNIT PRICE	EXTENDED PRICE
PRECOR COMMERCIAL TREADMILL 954	\$ 7,300.00	1	\$ 5,100.00	\$ 5,100.00
PRECOR COMMERCIAL EFX 556 ELLIPTICAL	\$ 5,800.00	1	\$ 4,300.00	\$ 4,300.00
TKO BIG BOY TRAINER STANDING HEAVY BAG	\$ 600.00	1	\$ 400.00	\$ 400.00
PRECOR FTS GLIDE	\$ 3,900.00	1	\$ 2,400.00	\$ 2,400.00
PRECOR POWER CAGE 610	\$ 1,150.00	1	\$ 1,000.00	\$ 1,000.00
PRECOR SUPERBENCH 119	\$ 900.00	2	\$ 700.00	\$ 1,400.00
TKO POWER TOWER: PULL UP/ DIP/ABDOMINAL	\$ 800.00	1	\$ 600.00	\$ 600.00
HAMPTON CP-3TA-2.5LB-50LB HEX RUBBER DB SET	\$ 1,700.00	1	\$ 1,350.00	\$ 1,350.00
PRECOR S LINE DUAL LEG EXTENSION/CURL	\$ 3,400.00	1	\$ 2,300.00	\$ 2,300.00
PRECOR S LINE DUAL PULLDOWN/ ROW	\$ 3,400.00	1	\$ 2,300.00	\$ 2,300.00
300LB OLYMPIC PLATE SET	\$ 400.00	1	\$ 300.00	\$ 300.00
OLYMPIC CURL BAR / 7OLY BAR	\$ 129.00	1 EACH	FREE	FREE
OPTI BALL 65CM/75 CM		1 EACH	FREE	FREE
STRETCHING MATS	\$ 40.00	3	\$ 25.00	\$ 75.00
PRECOR BACK EXTENSION PW312	\$ 745.00	1	\$ 625.00	\$ 625.00
ACCESSORY PACKAGE	\$ 400.00	1	\$ 450.00	\$ 450.00

**EQUIPMENT TOTAL** \$ 22,600.00

**Date of Quote:** September 5, 2011

**DELIVERY & INSTALLATION** \$ 700.00

**Preferred Delivery Date:** \_\_\_\_\_

**TOTAL (pre-tax)** \$ 23,300.00

**Quoted By:** RICH LEMOINE 305 815 7246

**TAX RATE** \_\_\_\_\_ **TAX EXEMPT**

**SALES TAX** \_\_\_\_\_ **TAX EXEMPT**

**\* Customer Terms:** full payment due upon placing order

**SUB TOTAL** \$ 23,300.00

Restocking Fee: 25% charge on all cancelled Cardio equipment.  
50% charge on all cancelled Strength equipment.

**FREIGHT** \$ 700.00

**Customer Notes:** PLEASE ALLOW UP TO 5 WEEKS FOR DELIVERY ON

**DEPOSIT** \_\_\_\_\_

SPECIAL ORDERED EQUIPMENT

**TOTAL AMOUNT** \$ 24,000.00

**Customer Approval:** \_\_\_\_\_

**Title:** \_\_\_\_\_ **Date:** \_\_\_\_\_

**\* ALL SPECIAL ORDERS ARE NON-REFUNDABLE**

\* A late payment fee of \$25 and monthly finance charges of 1.55% will be assessed on accounts not paid according to terms

\*By Signing this Quote you are agreeing to accept all terms and conditions stated above.

Broward Sheriff's Office  
**DANIA BEACH DISTRICT**



**PRECOR**

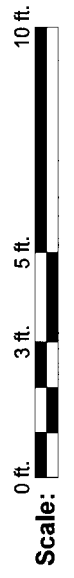
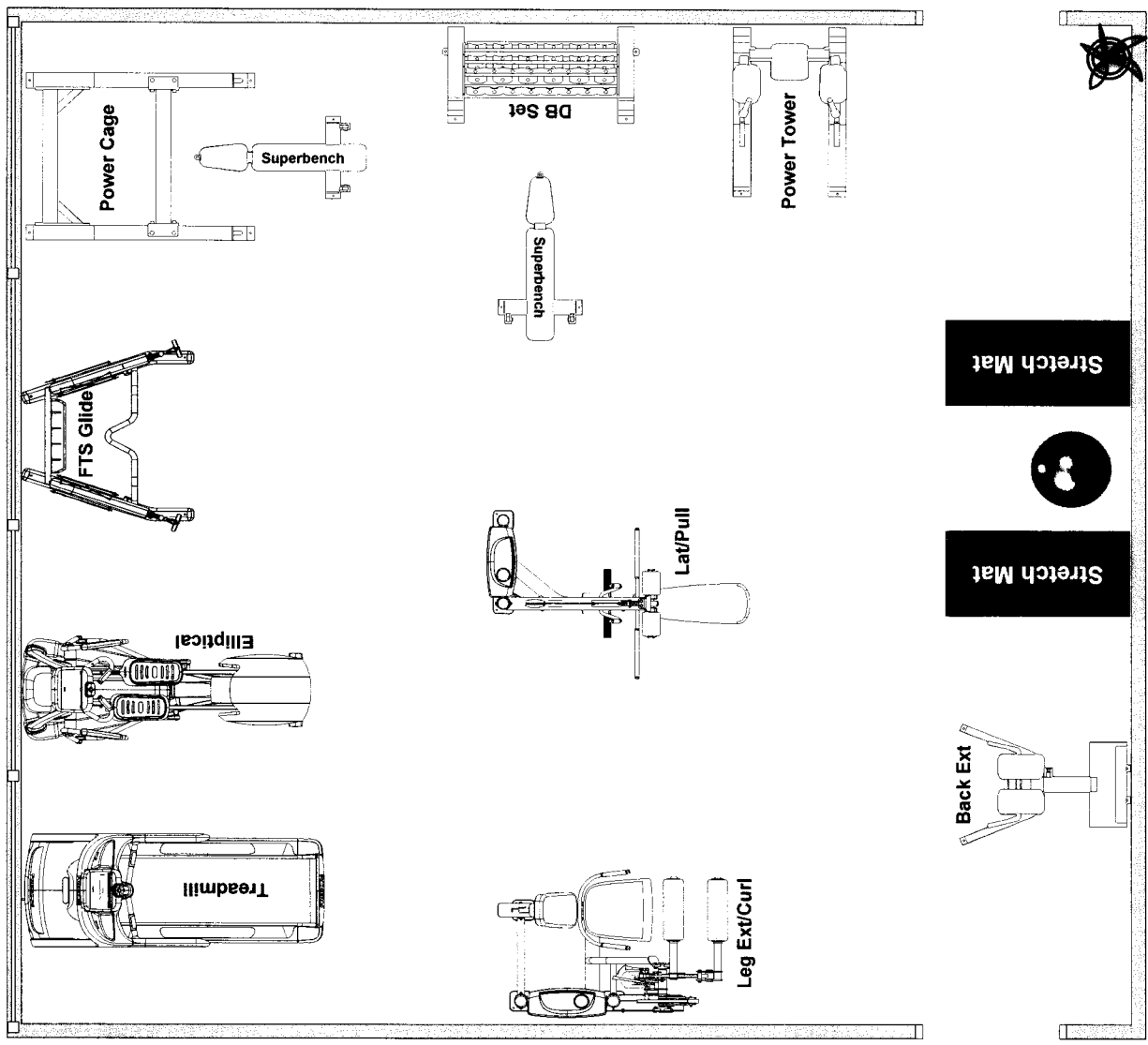
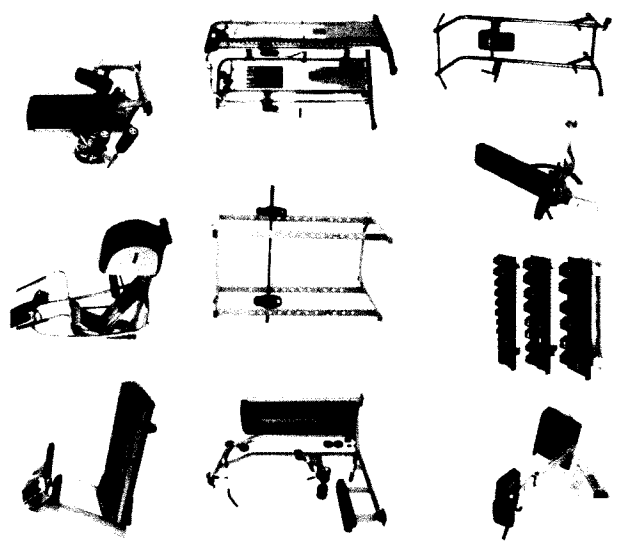

Contact: Rich Lemoine  
 Commercial Sales Manager  
 Busy Body Gyms To Go  
 Cell: 305-815-7246

**Bob Lawrence**

---

**From:** BOB LAWRENCE [BobL@GymSource.com]

**Sent:** Thursday, July 28, 2011 8:32 PM

**To:** Bob Lawrence

**Cc:** Bob Lawrence

**Subject:** Your Quote # 1302950



**QUOTE:** 1302950

07/28/2011  
Page 1 of 3

Salesperson	Store	Quote Dt	ACCOUNT ID	CUSTOMER NAME
BOB LAWRENCE	020	07/28/2011	20-72478	BROWARD SHERIFFS OFFICE

**Bill To**  
BROWARD SHERIFFS OFFICE  
DANIA BEACH DISTRICT  
4601 SW 30TH AVE  
FORT LAUDERDALE FL 33313

**Ship To**  
BROWARD SHERIFFS OFFICE  
DANIA BEACH DISTRICT  
4601 SW 30TH AVE  
FORT LAUDERDALE FL 33313

LN	Product	Description	List	Price	Qty	Total
1	TRU-CS500/BASE	TMILL-60X22/4HP/HRC/PROG	5449.00	3,412.50	1	3,412.50
2	TRU-CS500/CON-STD	CONSOLE-2 WINDOW/10 PRESET/IPOD COMPAT	650.00	.00	1	.00
3	TRU-CS800E/BASE	ELLIP- COMMERCIAL/HRC	5649.00	3,381.25	1	3,381.25
4	TRU-CS800E/CON-STD	CONSOLE-2 WINDOW/7 PRESET/IPOD COMPAT	650.00	.00	1	.00
5	TRU-CS800U/BASE	UPRIGHT BIKE COMMERCIAL	2049.00	1,495.00	1	1,495.00
6	TRU-CSBIKE/CON-STD	CONSOLE-2 WINDOW/7 PRESET/IPOD COMPAT	650.00	.00	1	.00
7	HOIST-PTS-ENS2/65P	KIT-SMITH/DUAL HILO/SHIELD/4165 BCH PS	4299.99	3,224.25	1	3,224.25
		--* kits comprised of *--				
	HOIST-PTS-1000/PS	SMITH-DUAL ACTION PLATINUM SPARKLE			1	
	HOIST-PTS-HILO/PS	HI-LO DUAL PULLEY W/DUAL 150LB PLAT SPAR			1	
	HOIST-HF-4165/PS	BENCH-FLAT/INC/DEC PS/SLATE			1	
	HOIST-PTS-SHIELD	WEIGHT STACK SHIELDS/PR.			2	
8	HOIST-HD-2300/CC	MID ROW/PULLDOWN V-PLATINUM	2599.00	1,949.25	1	1,949.25
9	HOIST-HD-2400/CC	SEATED LEG EXT/CURL V-PLATINUM	2999.00	2,249.25	1	2,249.25
10	HOIST-CF-2165/PS	BENCH-SUPER FID BENCH PLATINUM SPARKLE	799.00	599.25	1	599.25
11	HOIST-HF-4444/PS	RACK-OLY PLATE TREE	189.99	142.49	1	142.49
12	HOIST-CF-3461-3/PS	RACK-THREE TIER SDH RACK PLATINUM	1129.00	846.75	1	846.75
13	DB@GPU/S2-5-50	KIT-5-50LB URETHANE PROBELL SERII WSDU	2740.00	1,895.00	1	1,895.00
		--* kits comprised of *--				
	DB-GPU/S2-005	5LB URETHANE PROBELL SER II/EA. WSDU			2	
	DB-GPU/S2-010	10LB URETHANE PROBELL SER II/EA WSDU			2	
	DB-GPU/S2-015	15LB URETHANE PROBELL SER II/EA WSDU			2	
	DB-GPU/S2-020	20LB URETHANE PROBELL SER II/EA WSDU			2	
	DB-GPU/S2-025	25LB URETHANE PROBELL SER II/EA WSDU			2	

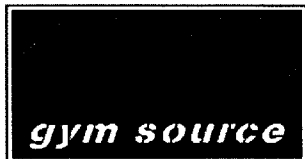

**QUOTE:** 1302950

07/28/2011  
Page 2 of 3

Salesperson	Store	Quote Dt	ACCOUNT ID	CUSTOMER NAME
BOB LAWRENCE	020	07/28/2011	20-72478	BROWARD SHERIFFS OFFICE

**Bill To**  
BROWARD SHERIFFS OFFICE  
DANIA BEACH DISTRICT  
4601 SW 30TH AVE  
FORT LAUDERDALE FL 33313

**Ship To**  
BROWARD SHERIFFS OFFICE  
DANIA BEACH DISTRICT  
4601 SW 30TH AVE  
FORT LAUDERDALE FL 33313

LN	Product	Description	List	Price	Qty	Total
	DB-GPU/S2-030	30LB URETHANE PROBELL SER II/EA WSDU			2	
	DB-GPU/S2-035	35LB URETHANE PROBELL SER II/EA WSDU			2	
	DB-GPU/S2-040	40LB URETHANE PROBELL SER II/EA WSDU			2	
	DB-GPU/S2-045	45LB URETHANE PROBELL SER II/EA WSDU			2	
	DB-GPU/S2-050	50LB URETHANE PROBELL SER II/EA WSDU			2	
14	DB-GPU/S2-055	55LB URETHANE PROBELL SER II/EA WSDU	249.00	186.75	2	373.50
15	DB-GPU/S2-060	60LB URETHANE PROBELL SER II/EA WSDU	254.00	190.50	2	381.00
16	DB-GPU/S2-065	65LB URETHANE PROBELL SER II/EA WSDU	259.00	194.25	2	388.50
17	DB-GPU/S2-070	70LB URETHANE PROBELL SER II/EA WSDU	264.00	198.00	2	396.00
18	PL-OLY-HOG-R45	45LB HAMPTON RUBBER GRIP PLATE	105.75	78.75	4	315.00
19	PL-OLY-HOG-R25	25LB HAMPTON RUBBER GRIP PLATE	58.75	43.75	4	175.00
20	PL-OLY-HOG-R10	10LB HAMPTON RUBBER GRIP PLATE	23.50	17.50	4	70.00
21	PL-OLY-HOG-R05	5LB HAMPTON RUBBER GRIP PLATE	11.75	8.75	4	35.00
22	COLLARS-OLY SPRING	OLY SPRING COLLARS/EA.OC-06	6.00	.00	4	.00
23	BARS-EZ-OLY	OLY EZ CURL BAR	68.00	40.00	1	40.00
24	DEL-INST	FREIGHT / DELIVERY / INSTALLATION		1,656.02	1	1,656.02
25		PAYMENT TERMS:				
26		30% DEPOSIT WITH ORDER				
27		BALANCE DUE AT DELIVERY				
28		SIGNATURE REQUIRED: _____				
29		PRINT NAME: _____				
30		DATE: _____				
31	PRE-ASSEMBLY	ITEMS MAY BE DEL'D ASSEMBLED		.00	1	.00
32	TIME	DISPATCH TO ASSIGN TIME WINDOW		.00	1	.00



**QUOTE:** 1302950

07/28/2011  
Page 3 of 3

Salesperson	Store	Quote Dt	ACCOUNT ID	CUSTOMER NAME
BOB LAWRENCE	020	07/28/2011	20-72478	BROWARD SHERIFFS OFFICE

**Bill To**  
BROWARD SHERIFFS OFFICE  
DANIA BEACH DISTRICT  
4601 SW 30TH AVE  
FORT LAUDERDALE FL 33313

**Ship To**  
BROWARD SHERIFFS OFFICE  
DANIA BEACH DISTRICT  
4601 SW 30TH AVE  
FORT LAUDERDALE FL 33313

LN	Product	Description	List	Price	Qty	Total
33		IT'S OUR PRIVILEGE TO SERVE YOU				
34	12 PT.CHECK LIST	12 POINT CHECKS COMPLETED		.00	1	.00

QUOTE IS VALID FOR 30 DAYS

<b>Subtotal</b>	<b>23,025.01</b>
<b>Tax</b>	<b>1,381.50</b>
<b>Total</b>	<b>24,406.51</b>

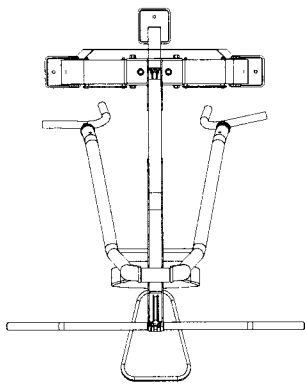

lat/low row

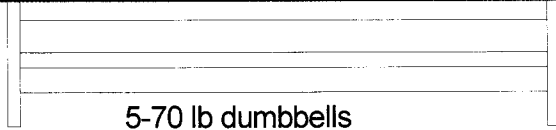

5-70 lb dumbbells

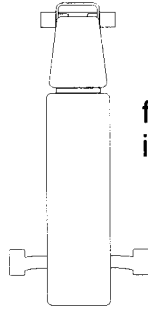

flat  
incline

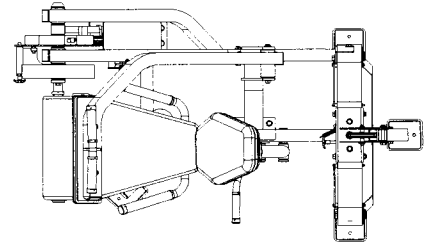

leg ext/curl

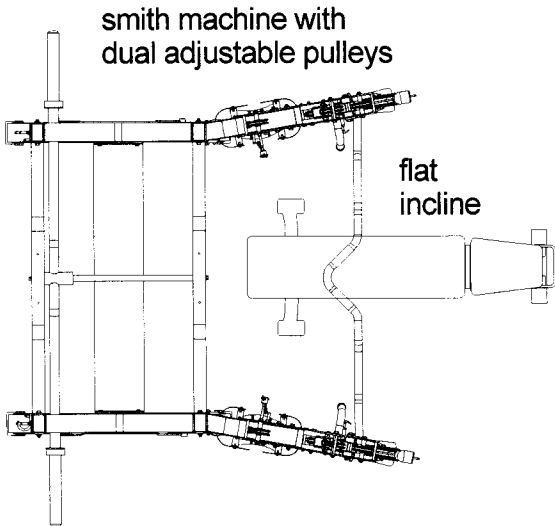

smith machine with  
dual adjustable pulleys

flat  
incline

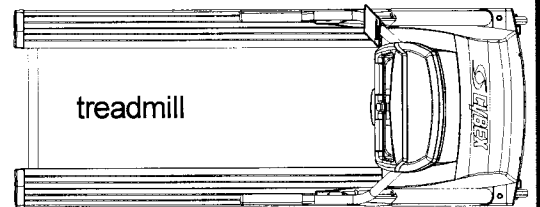

treadmill

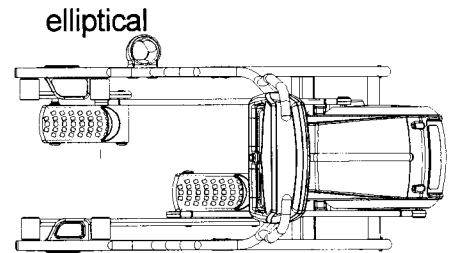

elliptical

plate tree

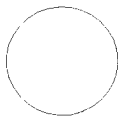
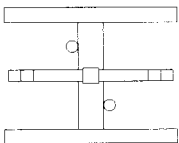

bike

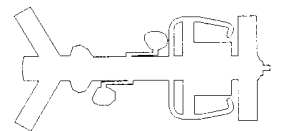





# LETF - State

Through 09/16/11

Detail Listing

Include Rollup Account/Rollup to Account & Sub-Account

Current YTD

Account	Account Description	Balance
Fund Category	Special Revenue	
Fund Type		
Fund	104 - Law Enforcement Trust Fund	
ASSETS		
104	Pooled Cash	
104-00	Operating	
104-00-00	Pooled Cash Operating Cash	67,787.62
	<b>104-00 - Operating Totals</b>	<b>\$67,787.62</b>
	<b>104 - Pooled Cash Totals</b>	<b>\$67,787.62</b>
115	Accts. Receivable	
115-07	Misc.	
115-07-00	Accts. Receivable Misc. AR	.00
	<b>115-07 - Misc. Totals</b>	<b>\$0.00</b>
	<b>115 - Accts. Receivable Totals</b>	<b>\$0.00</b>
131	Due from Other Funds	
131-00	Other Funds	
131-00-00	Due from Other Funds System Generated	.00
	<b>131-00 - Other Funds Totals</b>	<b>\$0.00</b>
	<b>131 - Due from Totals</b>	<b>\$0.00</b>
151	Investments - Current	
151-02	SBA	
151-02-00	Investments - Current SBA Accounts	890.33
	<b>151-02 - SBA Totals</b>	<b>\$890.33</b>
	<b>151 - Investments - Current Totals</b>	<b>\$890.33</b>
	<b>ASSETS TOTALS</b>	<b>\$68,677.95</b>
LIABILITIES AND FUND EQUITY		
LIABILITIES		
201	Vouchers Payable	
201-00	AP	
201-00-00	Vouchers Payable AP System Gen	.00
	<b>201-00 - AP Totals</b>	<b>\$0.00</b>
	<b>201 - Vouchers Payable Totals</b>	<b>\$0.00</b>
202	Accounts Payable	
202-00	AP	
202-00-00	Accounts Payable AP Manual	.00
	<b>202-00 - AP Totals</b>	<b>\$0.00</b>
202-01	AP	
202-01-00	Accounts Payable AP Manual	.00
	<b>202-01 - AP Totals</b>	<b>\$0.00</b>
	<b>202 - Accounts Payable Totals</b>	<b>\$0.00</b>
207	Due to Other Funds	
207-00	Due to	
207-00-00	Due to Other Funds Due to System Gen	.00
	<b>207-00 - Due to Totals</b>	<b>\$0.00</b>
	<b>207 - Due to Other Funds Totals</b>	<b>\$0.00</b>
	<b>LIABILITIES TOTALS</b>	<b>\$0.00</b>
FUND EQUITY		
243	Encumbrances	
243-01	Fund Equity	
243-01-00	Encumbrances Fund Equity Encumbrances	.00
	<b>243-01 - Fund Equity Totals</b>	<b>\$0.00</b>
	<b>243 - Encumbrances Totals</b>	<b>\$0.00</b>
245	Encumbrances	
245-01	Reserved for	
245-01-01	Encumbrances Reserved for Encumbrances	.00
245-01-02	Encumbrances Reserved for Prior-Year Encumbrances	.00
	<b>245-01 - Reserved for Totals</b>	<b>\$0.00</b>
	<b>245 - Encumbrances Totals</b>	<b>\$0.00</b>
271	Fund Balance	
271-00	Unreserved	
271-00-00	Fund Balance Unreserved Fund Balance	51,541.00
	<b>271-00 - Unreserved Totals</b>	<b>\$51,541.00</b>
	<b>271 - Fund Balance Totals</b>	<b>\$51,541.00</b>
	<b>FUND EQUITY TOTALS Prior to Current Year Changes</b>	<b>\$51,541.00</b>
	Prior Year Fund Equity Adjustment	.00
	Fund Revenues	(21,755.95)
	Fund Expenses	4,619.00
	<b>FUND EQUITY TOTALS</b>	<b>\$68,677.95</b>
	<b>LIABILITIES AND FUND EQUITY TOTALS</b>	<b>\$68,677.95</b>
Fund	104 - Law Enforcement Trust Fund Totals	\$0.00
	Fund Type Totals	\$0.00
Fund Category	Special Revenue Totals	\$0.00
	Grand Totals	\$0.00



**LETF - Federal**  
 Through 09/16/11  
 Detail Listing  
 Only Show Rollup Account/Rollup to Account & Sub-Account

Account \_\_\_\_\_ Account Description \_\_\_\_\_

Fund Category **Special Revenue**

Fund Type

Fund **109 - LETF - Federal Equitable Sharing**

**104** ASSETS  
**Pooled Cash**  
 104-00 Operating

131,295.16  
**104 - Pooled Cash Totals** \$131,295.16  
 ASSETS TOTALS \$131,295.16

**FUND EQUITY**

**271 Fund Balance**  
 271-00 Unreserved

131,295.16  
**271 - Fund Balance Totals** \$131,295.16  
 FUND EQUITY TOTALS Prior to Current Year Changes \$131,295.16

Fund Revenues  
 Fund Expenses

.00  
 .00  
 .00  
**FUND EQUITY TOTALS** \$131,295.16  
 LIABILITIES AND FUND EQUITY TOTALS \$131,295.16  
 Fund **109 - LETF - Federal Equitable Sharing** Totals \$0.00  
 Fund Type Totals \$0.00  
 Fund Category **Special Revenue** Totals \$0.00  
 Grand Totals \$0.00